

SCHOPF F210 Aircraft Tow Tractor



SCHOPF

Tractors. Loaders. Stairs. And more.

Technical data SCHOPF F210

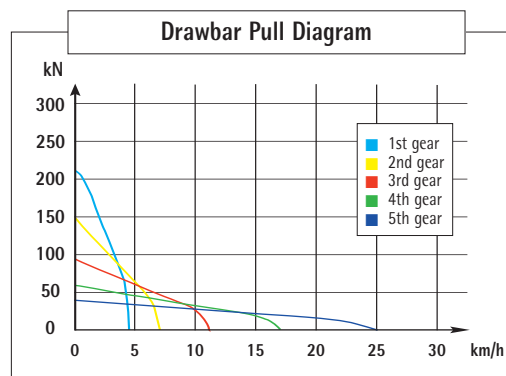
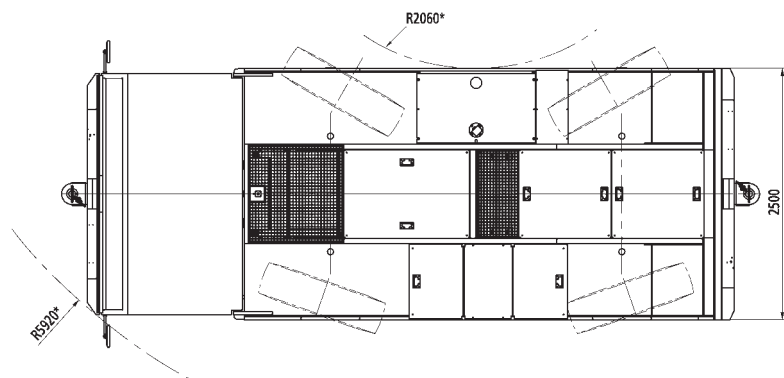
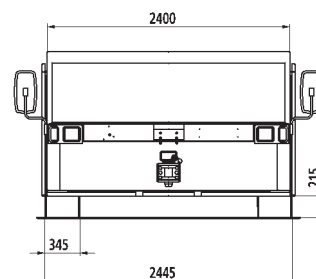
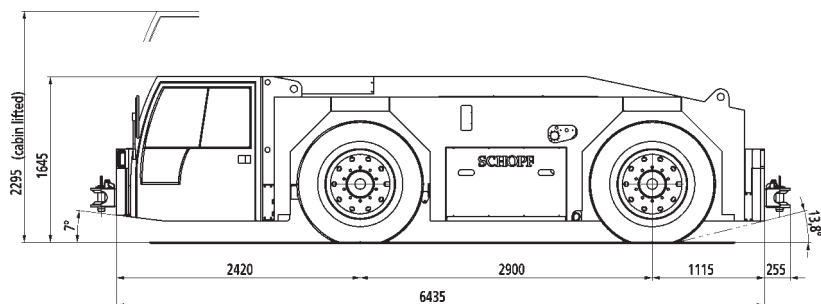

General data

- Operating weights 22,000/26,000/30,000/32,000* kg
- Draw-bar pull (installed) 210 kN (47,210 lbs)
- Tyre size 12.00 x 24
(*Speed of the 32,000 kg version is limited to 17 km/h)

Engine

Water-cooled Deutz TCD 2012 L06, turbo-charged, 6-cylinder, in-line Diesel, exhaust gas emissions acc. to latest standards, 155 kW (211 HP) at 2,300 rpm, 810 Nm at 1,600 rpm, 6,057 cm³, integrated engine management system (EMR)

Transmission

ZF ERGOPOWER series 5WG-190, fully automatic full-power-shift transmission, reversing, integrated torque converter, electro-hydraulic gear shifting, 5 gears forward, 3 gears reverse

Brakes

- Fully hydraulic 3-circuit safety disk brake system with accumulator backup:
 - 2-circuit service brake
 - 1-circuit failsafe parking/emergency (spring on hydraulic pressure release) brake
 - Circuit protection valves for safe braking in case of main hydraulic pump failure

Steering system

- Hydraulic Orbitrol steering system with electrically selected and return-to-centreline-control modes:
 - Front wheel
 - Rear wheel
 - 4-wheel co-ordinated
 - Crab steering (option)

Electric system

- Alternator 28 V / 55 A
- Battery capacity 2 x 12 V / 143 Ah
- Engine starter 4 kW

- 2 headlights, low and high beam

- 2 LED reversing lights
- 2 LED brake lights
- 2+2 directional indicator LED lights (front + rear)

Options

- Rear driver's cabin
- Rear driver's stand
- GPU platform
- Various tow hitches
- Air-conditioning
- Winterization kits
- Heating systems
- Cabin-roof light barrier or antenna sensor
- 4 integrated hydraulic jacks
- Rear-view video camera
- And more...

Tolerance of mentioned data +/- 3%. Specifications subject to change without notice. Drawings and pictures may include options.

